

道路用側溝 土留型

GPUD2歩道用
GPUD3車道用

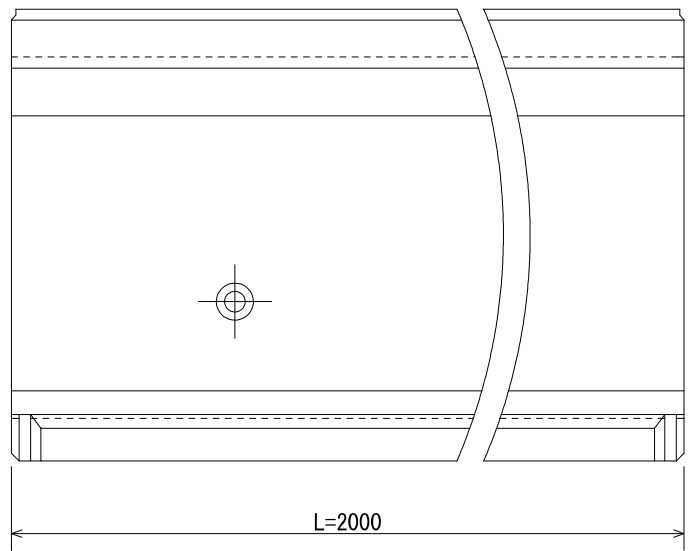
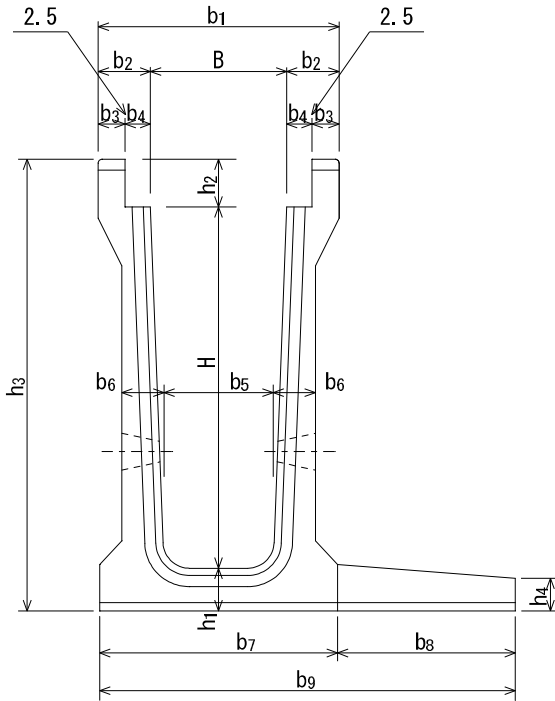
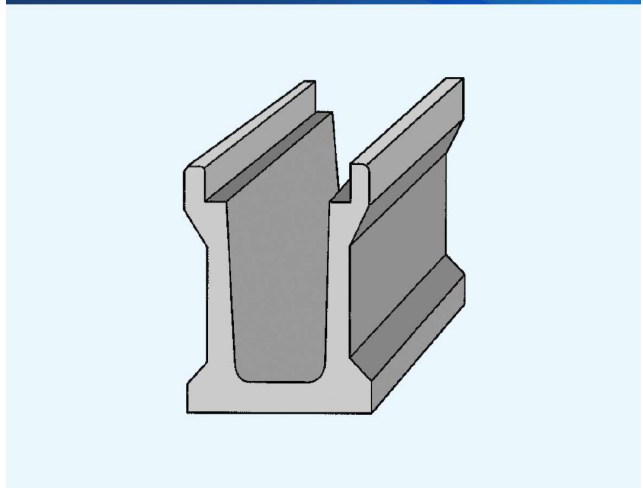

呼び名	寸法 (mm)															参考重量 (kg)
	B	H	b ₁	b ₂	b ₃	b ₄	b ₅	b ₆	b ₇	b ₈	b ₉	h ₁	h ₂	h ₃	h ₄	
GPUD $\frac{2}{3}$ -30-60	300	600	535	117.5	60	55	250	80	535	300	835	80	100	780	75	845
GPUD $\frac{2}{3}$ -30-70	300	700	535	117.5	60	55	245	85	535	350	885	85	100	885	76	967
GPUD $\frac{2}{3}$ -30-80	300	800	535	117.5	60	55	240	90	535	400	935	90	100	990	76	1099
GPUD $\frac{2}{3}$ -30-90	300	900	535	117.5	60	55	235	95	535	450	985	95	100	1095	76	1237
GPUD $\frac{2}{3}$ -30-100	300	1000	535	117.5	60	55	230	100	535	450	985	100	100	1200	80	1368
GPUD $\frac{2}{3}$ -40-60	400	600	635	117.5	60	55	350	80	635	300	935	80	110	790	75	889
GPUD $\frac{2}{3}$ -40-70	400	700	635	117.5	60	55	345	85	635	350	985	85	110	895	76	1014
GPUD $\frac{2}{3}$ -40-80	400	800	635	117.5	60	55	340	90	635	400	1035	90	110	1000	76	1148
GPUD $\frac{2}{3}$ -40-90	400	900	635	117.5	60	55	335	95	635	450	1085	95	110	1105	76	1289
GPUD $\frac{2}{3}$ -40-100	400	1000	635	117.5	60	55	330	100	635	450	1085	100	110	1210	80	1422
GPUD $\frac{2}{3}$ -50-70	500	700	755	127.5	65	60	445	90	755	350	1105	90	125	915	76	1145
GPUD $\frac{2}{3}$ -50-80	500	800	755	127.5	65	60	440	90	755	400	1155	90	125	1015	76	1234
GPUD $\frac{2}{3}$ -50-90	500	900	755	127.5	65	60	435	95	755	450	1205	95	125	1120	76	1377
GPUD $\frac{2}{3}$ -50-100	500	1000	755	127.5	65	60	430	100	755	450	1205	100	125	1225	80	1512

* GPUD2とGPUD3は鉄筋量を変えて対応できます。